

## SPECIFICATION

■ MAX POWER OUTPUT.....	160W
■ Crossover .....	30-160Hz (-12dB/oct)
■ PHASE .....	0°, 180°
■ INPUT SENSITIVITY .....	80mV-0.5V (Line Input) 0.9V-6V (Speaker Input)
■ OPERATIONAL VOLTAGE .....	DC 14.4V (Operational between: 11~16V)
■ DIMENSIONS .....	342mmX238mmX80mm
■ WEIGHT.....	5 Kg

## SUBWOOFER INSTALLATION

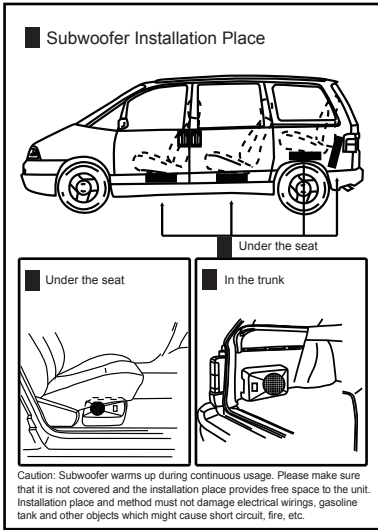

1. Mount the installation bracket onto the bottom of the subwoofer (4 brackets, 4 screws).
2. Fix the brackets on the body of the vehicle (4 brackets, 4 screws).

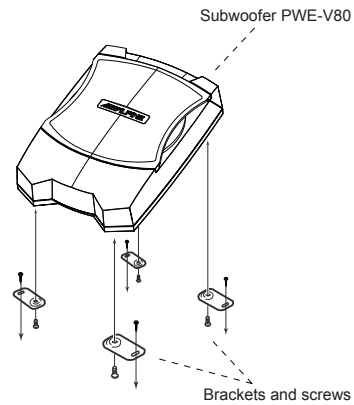

# ALPINE

## 8 INCH SUPER COMPACT ACTIVE SUBWOOFER

# PWE-V80

## Instruction Manual



## ACCESSORIES

■ Line controller



■ Remote start wire



■ 10P connection couple  
(Power line, remote start wire,  
speaker input wire, ground wire)



■ Mounting bracket



■ 5M power extension coupler (12AWG)



■ Fixed screw (locking vehicle)



■ Speaker output wire



■ Fixed screw (locking body)



## 1. CONNECTION

- This product cannot be used in cars fitted with a common negative speaker system.
- To prevent external noise from entering the audio system:
  - Locate the unit and route the leads at least 10 cm away from the car harness.
  - Keep the power lines as far away from other leads as possible.
  - Connect the ground lead securely and safely to a bare metal spot (remove the coating if necessary) of the car chassis.
  - If you add an optional noise suppressor, connect it as far away from the unit as possible. Your Alpine Dealer can provide various noise suppressor solutions, contact them for further information.
- Your Alpine Dealer knows best about noise prevention measures so consult your dealer for further information.
- Ensure secure connections.
- Any unused connections should be insulated with electrical insulation tape.
- If the on-board computer or similar device, such as the ECU, contains security code, you may lose the memory when connecting the negative lead.

1 Disconnect the cable from the negative terminal of the car battery.

2 Connect

### • CONNECTIONS FOR RCA INPUT

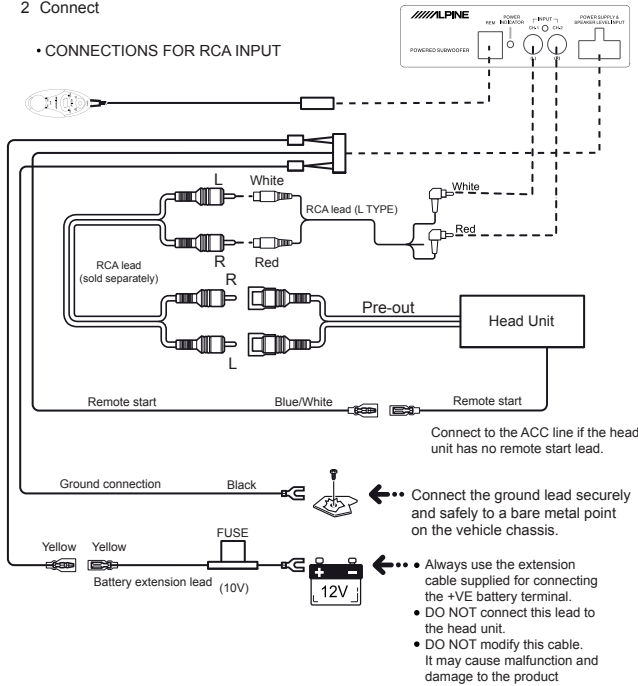

### • CONNECTIONS FOR SPEAKER LEVEL INPUT

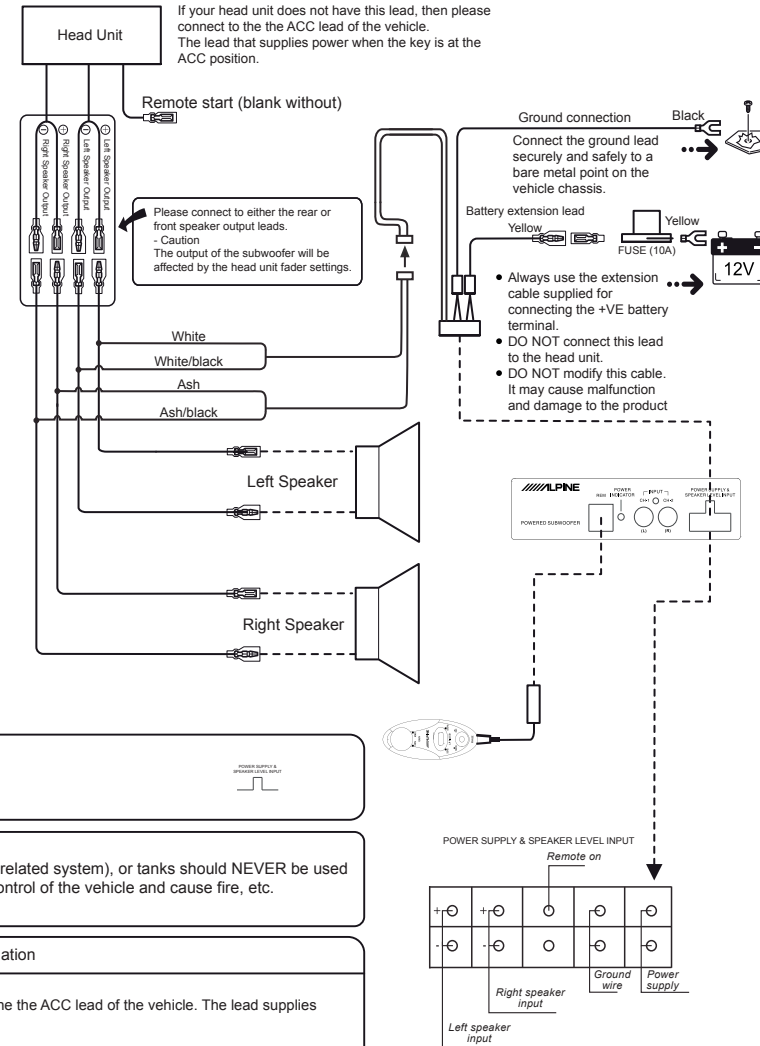

## 2. ADJUSTMENT

**CAUTION** If there is distortion or you hear a popping sound from the subwoofer, the input level is too high. If the subwoofer has prolonged use in this condition, this may result in deterioration of performance or may cause damage to the subwoofer.

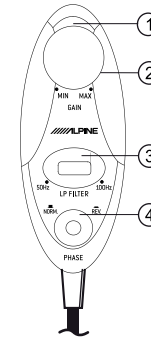

- 1 POWER INDICATOR
- 2 INPUT GAIN ADJUSTMENT
- 3 LOW PASS FILTER ADJUSTMENT
- 4 PHASE SELECTOR

1. Set the gain to MIN, Phase to NORM.LPF to CENTER before swithing on the system.
2. Set the Bass/Treble adjustment to zero on the head unit. Set the volume to your average listening level. It may help to use a music source that is familiar.
3. Next, gradually increase the gain level and system volume to a point where system balance is achieved. If the gain level is set too high, the subwoofer may begin to distort. Distortion may also occur if the volume is set too high on the head unit. Check that the other speakers have not begun to distort before proceeding with the adjustment. If the entire speaker system in the car is distorting, reduce the volume of the head unit.
4. Once the gain has been set, adjust the L.P.F (Low Pass Filter) at afrequency which compliments your speaker system. (We recommend using CENTER as a starting point.)
5. Adjusting the L.P.F will change the output volume of the subwoofer. Repeat procedures 3 and 4 until the ideal setting is found.
6. The final adjustment is the PHASE of the subwoofer. While sitting in the driver's seat and with music playing, switch to a better setting between NORM and REV - The ideal PHASE setting varies from car to car, depending on the location of the subwoofer and the interior acoustic characteristics of the car.



Failure to do so may result in fire, accident or electrical shock.



Bolts or nuts used for the brake or steering systems (or any other safety related system), or tanks should NEVER be used for installations or ground connections. Using such parts could disable control of the vehicle and cause fire, etc.

Type of Lead	Additional Information
Remote turn on lead	Connect to the remote start lead of the head unit. • If your head unit does not have this lead, then please connect to the the ACC lead of the vehicle. The lead supplies power when the key is in the ACC position.
Ground lead	Attach securely and safely to a bare metal spot on the car's chassis.
Power line	Connect directly to the positive terminal of the car's battery.